

SEMI AUTOMATIC POLISHING MACHINE SPM

EDAB
AUTOMATION

EDAB Automation introduces the most reliable and lowest cost Semiautomatic Polishing Machine to the stone industry. It allows to polish materials such as marble and granite.



MAIN BENEFITS

- Maximum minimalization of polishing costs
- Better comfort for the operator than polishing on CNC routers
- Simple operation
- Installation directly on the floor
- Polishing with cylinders or frontal pads
- No CNC controlling

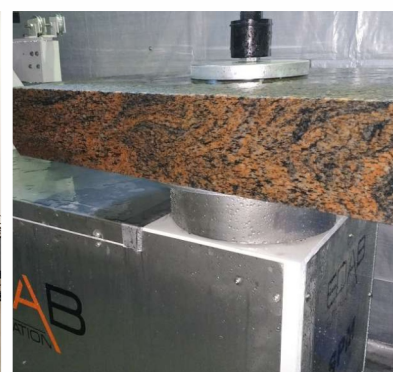

WORKING GRAPHICS

EDAB
AUTOMATION

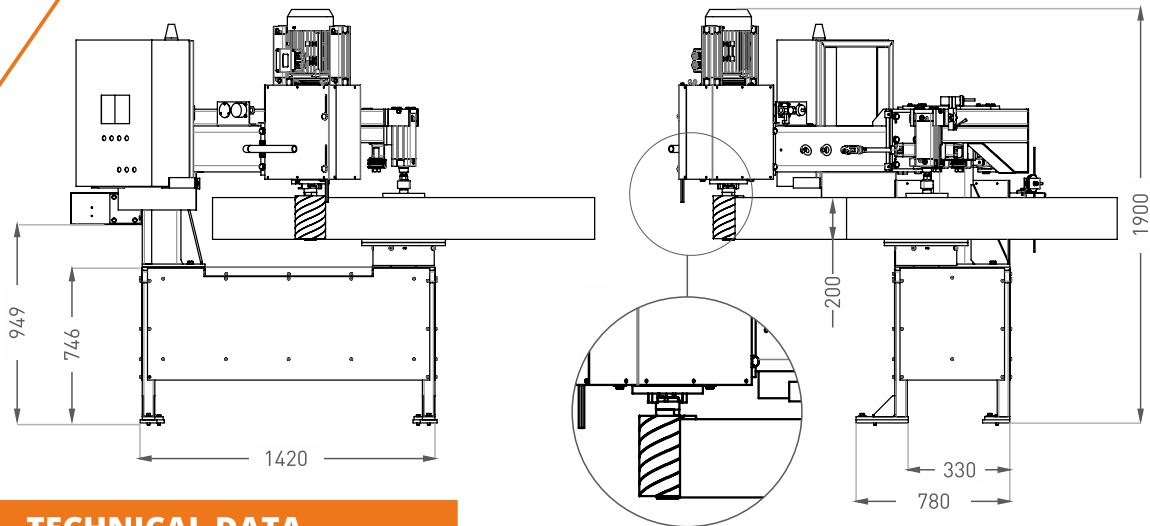

TECHNICAL DATA

Max piece dimension	1400 x 1400 mm
Max piece thickness	200 mm
Power	5 kW
Water demand	25 l/mln
Air demand	10 l/mln
Water flow sensor Spindle inverter Table inverter Pneumatic arm tensioning Air pressure sensor Acoustic information about finished work	

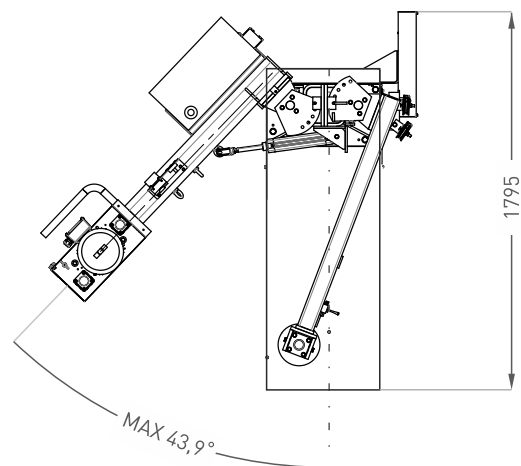

SIEMENS

Software, studied and developed for the stone, is easy to learn and is updated constantly. Advanced checkup and diagnostics system. Worldwide customer service. Our software is digital, high-tech PLC system that makes it possible to make better use of electro-mechanical properties of EDAB machine and to achieve higher machining speeds with the highest precision.



Watch video

and find out more about

EDAB SEMI AUTOMATIC POLISHING MASHINE SPM



CONTACT US



OFFICE | GERMANY
EDAB Automation UG
 Birnbaumsmühle 65
 15234 Frankfurt (Oder)



OFFICE & WORKSHOP | POLAND
BOLEDAN
 Powstańców Wielkopolskich 13
 69-100 Słubice



CEO: Edgar Dabrowski | +48 692 404 414 | info@edabautomation.com

 [edabautomation](https://www.facebook.com/edabautomation)

www.edabautomation.com